

Over Voltage Protection

ESD Guard™

EGA Series

| | |
|--------------------------------|---|
| Introduction..... | 3 |
| Specifications..... | 4 |
| Environmental Performance..... | 4 |
| Package..... | 4 |

ESD Array

EGA Array Series

| | |
|--------------------------------|---|
| Introduction..... | 5 |
| Specifications..... | 6 |
| Environmental Performance..... | 6 |
| Package..... | 6 |

TVU Series

| | |
|--------------------------------|---|
| Introduction..... | 7 |
| Specifications..... | 8 |
| Environmental Performance..... | 8 |
| Package..... | 8 |

Transient Voltage Suppressor

TVS Series

| | |
|--|-------|
| Introduction..... | 9 |
| Specifications..... | 10 |
| Environmental Performance..... | 11 |
| Pin Configuration and Circuit Diagram..... | 12-13 |
| Package..... | 14 |

Multilayer Varistor

MLVS Series

| | |
|--------------------------------|----|
| Introduction..... | 15 |
| Specifications..... | 16 |
| Environmental Performance..... | 17 |
| Package..... | 17 |

MLVG Series

| | |
|--------------------------------|----|
| Introduction..... | 18 |
| Specifications..... | 19 |
| Environmental Performance..... | 19 |
| Package..... | 19 |







MLF Series

| | |
|--------------------------------|----|
| Introduction..... | 20 |
| Specifications..... | 21 |
| Environmental Performance..... | 21 |
| Package..... | 21 |

EMI / ESD Suppressor

VPORT Series

| | |
|--------------------------------|----|
| Introduction..... | 22 |
| Specifications..... | 23 |
| Environmental Performance..... | 24 |
| Package..... | 24 |

| Over Voltage Protection | | | | |
|---|------------------------------|-----------|------------------------------|------------------------------|
| Product ID | Product Name | Series | Size (EIA) | Size (EIAJ) |
|  | ESD Guard™ | EGA | 0201 0402 0603 | 0603 1005 1608 |
|  | ESD Array | EGA Array | 1206 | 3216 |
|  | | TVU | 1004 1210 | 2510 3025 |
|  | Transient Voltage Suppressor | TVS | 0201 0402 — | 0603 1608 — |
|  | Multilayer Varistor | MLVS | 0201 0402 0603 1206 | 0603 1005 1608 3216 |
|  | | MLVG | 0402 0603 | 1005 1608 |
|  | | MLF | 0402 0603 | 1005 1608 |
|  | EMI / ESD Suppressor | VPORT | 0402 0603 | 1005 1608 |

Specifications



Features

- Protection against high ESD voltage and current (IEC61000-4-2 Level 4)
- Compact size for EIA 0201, 0402 and 0603
- Extremely quick response time (<1ns)
- Extremely low capacitance (<0.5pF)
- Extremely low leakage current
- Zero signal distortion
- Bi-directional

Applications

- **EGA10402V05AH, EGA10402V12A0, EGA10603 Series** are applied to RF module, Antenna circuit, IEEE-1394, USB2.0, DVI, HDMI, DisplayPort and high speed signal interface etc.
- **EGA10201V00A3** is recommended to use the application of RF antenna front-end circuit without DC bias.

How to Order

EGA 1 0603 V05 A1 - B

1 2 3 4 5 6

- 1 Series Type : ESD Guard™ Series
- 2 Elements Type
- 3 Chip Size (EIA) : 0201/0402/0603
- 4 Rated Voltage, V_{DC}
- 5 Model Code
- 6 Suffix for Special Code

Dimensions

Unit: mm

| Size EIA (EIAJ) | 0201 (0603) | 0402 (1005) | 0603 (1608) |
|-----------------|-------------|-------------|-------------|
| L | 0.6±0.03 | 1.00±0.1 | 1.60±0.10 |
| W | 0.3±0.03 | 0.50±0.1 | 0.80±0.10 |
| H | 0.3±0.03 | 0.34±0.1 | 0.50±0.10 |
| B | 0.15±0.05 | 0.20±0.1 | 0.30±0.20 |

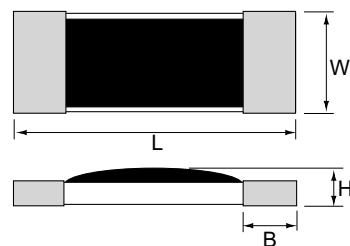

Circuit Symbol



Specifications

| Characteristic\Part No. | Symbol | Unit | EGA10201V00A3 ¹ | EGA10201V05A0* | EGA10402V05AH | EGA10402V12A0 |
|---|-----------------|--------|----------------------------|----------------|---------------|---------------|
| Maximum Operating Voltage | V _{bc} | V | Without DC Bias, RF Only | 5 | 5 | 12 |
| Leakage Current ² | I _L | μA | 0.01 typ. | 0.01 typ. | 0.05 typ. | 0.05 typ. |
| Capacitance ³ , @1MHz | C _p | pF | 0.2 typ. | 0.2 typ. | 0.2 typ. | 0.2 typ. |
| Trigger Voltage | V _t | V | 140 typ. | 250 typ. | 150 typ. | 300 typ. |
| Clamping Voltage ⁴ | V _c | V | 35 typ. | 30 typ. | 30 typ. | 30 typ. |
| ESD Voltage Capacity, Contact Discharge Mobile | KV | V | 8 typ. | 8 typ. | 8 typ. | 8 typ. |
| ESD Voltage Capacity, Air Discharge Mobile | KV | V | 15 typ. | 15 typ. | 15 typ. | 15 typ. |
| ESD Pulse Withstand | | Pulses | 1000 typ. | 1000 typ. | 1000 typ. | 1000 typ. |

| Characteristic\Part No. | Symbol | Unit | EGA10603V05A1-B | EGA10603V12A1-B | EGA10603V24A0 |
|---|-----------------|--------|-----------------|-----------------|---------------|
| Maximum Operating Voltage | V _{bc} | V | 5 | 12 | 24 |
| Leakage Current ² | I _L | μA | 0.01 typ. | 0.01 typ. | 0.01 typ. |
| Capacitance ³ , @1MHz | C _p | pF | 0.2 typ. | 0.2 typ. | 0.25 typ. |
| Trigger Voltage | V _t | V | 150 typ. | 150 typ. | 300 typ. |
| Clamping Voltage ⁴ | V _c | V | 30 typ. | 30 typ. | 30 typ. |
| ESD Voltage Capacity, Contact Discharge Mobile | KV | V | 8 typ. | 8 typ. | 8 typ. |
| ESD Voltage Capacity, Air Discharge Mobile | KV | V | 15 typ. | 15 typ. | 15 typ. |
| ESD Pulse Withstand | | Pulses | 1000 typ. | 1000 typ. | 1000 typ. |

Notes:

- EGA10201V00A3 is recommended to use the application of RF antenna front end circuit without DC bias.
- Leakage current at maximum operating voltage.
- Capacitance is measured with 1V_{rms}.
- Per IEC 61000-4-2, 30A@8KV, level 4, clamp measurement made 30 ns after initiation of pulse, all test in contact discharge mode.

*- Preliminary

General Technical Data

| | |
|-----------------------|------------------|
| Operating Temperature | -40°C ~ +85°C |
| Storage Temperature | -55°C ~ +125°C |
| Response Time | <1 ns |
| Solderability | 245±5°C, 3±1sec. |

Environmental Performance

| Item | Specifications | Test Condition |
|-------------------------|-----------------------|--|
| Bias Humidity | I _L ≤ 10μA | 90%RH, 40°C, Rated Voltage, 1000 hr |
| Thermal Shock | | -40°C to 85°C, 30 min. cycle, 5 cycles |
| Full Load Voltage | | Rated Voltage, 85°C, 1000 hr |
| Solder Leach Resistance | | 260±5°C, 10±1sec. |

I_L – Leakage current at rated voltage, the maximum leakage current was measured after reliability test.

Package

| Size EIA (EIAJ) | 0201 (0603) | 0402 (1005) | 0603 (1608) |
|--|-------------|-------------|-------------|
| Standard Packing Quantity (pcs / reel) | 15,000 | 10,000 | 5,000 |



► **Features**

- Protection against ESD voltages and currents (IEC61000-4-2 Level 4)
- Extremely quick response time (<1ns) present ideal ESD protection
- Extremely low capacitance (0.25pF typical)
- Extremely low leakage current
- Bi-directional device
- SMD (Surface Mount Device)
- Zero signal distortion

► **Applications**

EGA Array is applied to RF module, Antenna circuit, IEEE-1394, USB2.0, DVI, HDMI, DisplayPort and high speed signal interface etc.

► **How to Order**

EGA **4** **1206** **V12** **A**

1 2 3 4 5 6

- 1 Series Type : ESD Guard™ Series
- 2 Elements Per Chip
- 3 Chip Size (EIA) : 1206
- 4 Rated Voltage, V_{DC}
- 5 Model Code
- 6 Suffix for Special Code

► **Dimensions**

Unit: mm

| Size EIA (EIAJ) | 1206 (3216) |
|-----------------|-------------|
| L | 3.20±0.1 |
| W | 1.60±0.1 |
| H | 0.50±0.1 |
| B | 0.40±0.2 |
| C | 0.40±0.2 |
| D | 0.20±0.1 |

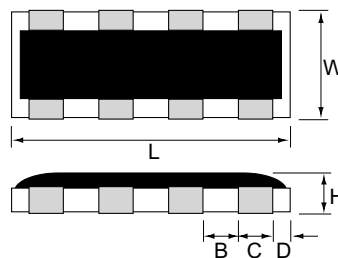

Circuit Symbol

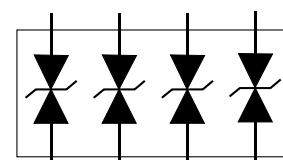

Specifications

| Characteristic\Part No. | Symbol | Unit | EGA41206V12A0 |
|--|-----------------|--------|---------------|
| Maximum Operating Voltage | V _{DC} | V | 12 |
| Leakage Current ¹ | I _L | μA | 0.01 typ. |
| Capacitance ² , @1MHz | C _p | pF | 0.25 typ. |
| Trigger Voltage | V _t | V | 300 typ. |
| Clamping Voltage ³ | V _c | V | 30 typ. |
| Response time | | ns | 1 max. |
| ESD Voltage Capability, Contact Discharge Mode | | KV | 8 typ. |
| ESD Voltage Capability, Air Discharge Mode | | KV | 15 typ. |
| ESD Pulse Withstand | | Pulses | 1000 typ. |

Notes:

1. Leakage current at maximum operating voltage.
2. Capacitance is measured with 1V_{rms}.
3. Per IEC 61000-4-2, 30A@8KV, level 4, clamp measurement made 30 ns after initiation of pulse, all test in contact discharge mode.

General Technical Data

| | |
|-----------------------|-----------------|
| Operating Temperature | -40°C ~ +85°C |
| Storage Temperature | -55°C ~ +125°C |
| Response Time | <1 ns |
| Solderability | 245±5°C, 3±1sec |

Environmental Performance

| Item | Specifications | Test Condition |
|-------------------------|------------------------|--|
| Bias Humidity | I _L ≤ 10 μA | 90%RH, 40°C, Rated Voltage, 1000 hrs |
| Thermal Shock | | -40°C to 85°C, 30 min. cycle, 5 cycles |
| Full Load Volage | | Rated Voltage, 85°C, 1000 hrs |
| Solder Leach Resistance | | 260±5°C, 10±1sec. |

I_L – Leakage current at rated voltage, the maximum leakage current was measured after reliability test.

Package

| | |
|--|-------------|
| Size EIA (EIAJ) | 1206 (3216) |
| Standard Packing Quantity (pcs / reel) | 5,000 |



Features

- Protection against ESD voltages and currents (IEC61000-4-2 Level 4)
- Extremely quick response time (<1ns) present ideal ESD protection
- Extremely low capacitance (0.1pF typical)
- Extremely low leakage current
- SMD (Surface Mount Device)
- Zero signal distortion

Applications

- TVU Series is applied to high speed signal interface, including Antenna circuit, USB2.0, IEEE-1394, DVI and HDMI.
- Suitable for Digital Video Equipment Mobile Phone, GPS Antenna, and Bluetooth Communication Equipment.

How to Order

TVU **12** **4** **0R1** **A**
1 2 3 4 5

- 1 TVU : Ultra Capacitance
- 2 Working Voltage : V_{DC} 12V
- 3 Channel : 4 channels
- 4 Capacitance : 0.1pF
- 5 Chip Size : L: 2.5mm W: 1.0mm

TVU **12** **05** **0R1** **C** **0**
1 2 3 4 5 6

- 1 TVU : Ultra Capacitance
- 2 Working Voltage : V_{DC} 12V
- 3 Channel : 5 channels
- 4 Capacitance : 0.1pF
- 5 Chip Size : L: 3.0mm W: 2.5mm
- 6 Type

Dimensions

Unit: mm

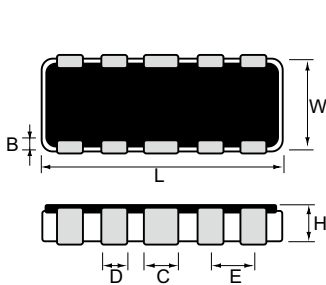

Circuit Symbol

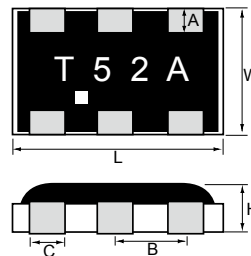
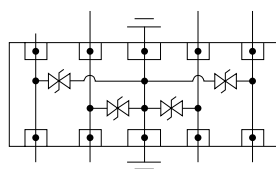

Circuit Symbol

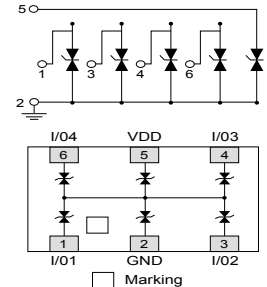

TVU1240R1A

| Size EIA (EIAJ) | 1004 (2510) |
|-----------------|-------------|
| L | 2.5±0.1 |
| W | 1.0±0.1 |
| T | 0.5±0.1 |
| B | 0.2±0.1 |
| C | 0.3±0.05 |
| D | 0.2±0.05 |
| E | 0.5±0.05 |

TVU12050R1C0, TVU12050R1C1

| Size EIA (EIAJ) | 1004 (2510) |
|-----------------|-------------|
| L | 3.0±0.1 |
| W | 2.5±0.1 |
| H | 0.6(max) |
| A | 0.4±0.15 |
| B | 0.95±0.1 |
| C | 0.4±0.1 |

T - Product code
 5 - Channel amount
 2 - Ground pin site
 A or B - Special code

 A for TVU12050R1C0
 B for TVU12050R1C1

Specifications

| Characteristic | Symbol | Unit | TVU1240R1A | TVU12050R1C0 | TVU12050R1C1 |
|--|----------------|--------|--------------------|------------------------|------------------------|
| Rated voltage | | V | 12 max. | 12 max. | 12 max. |
| Leakage current | I _L | μA | 0.01 max. (@12VDC) | 1.0 (@6VDC) | 1.0 (@6VDC) |
| Trigger voltage | V _t | V | 300 typ. | 300 typ. | 300 typ. |
| Clamping voltage | V _c | V | 30 typ. | 30 typ. | 30 typ. |
| Capacitance @1MHz | C _p | pF | 0.1 typ. | 0.1pF typ. ,0.2pF max. | 0.1pF typ. ,0.2pF max. |
| ESD voltage capability, IEC 61000-4-2 Contact discharge mode | | KV | 10 typ. | 8 typ. | 10 typ. |
| ESD voltage capability, IEC 61000-4-2 Air discharge mode | | KV | 15 typ. | 15 typ. | 15 typ. |
| ESD withstand pulses | | Pulses | 100 typ. | 100 typ. | 100 typ. |
| Peak pulse current (tp=8/20 μs, for V _{dd} only) | | A | NA | 6 | 6 |

C_p–Device capacitance measured with 1Vrms

General Technical Data

| | |
|-----------------------|------------------|
| Operating Temperature | -40°C ~ +85°C |
| Storage Temperature | -55°C ~ +125°C |
| Response Time | <1 ns |
| Solderability | 245±5°C, 3±1sec. |

Environmental Performance

| Item | Specifications | Test Condition |
|-------------------------|----------------------|--|
| Bias Humidity | I _L ≤10μA | 90%RH, 40°C, Rated Voltage, 1000 hrs |
| Thermal Shock | | -40°C to 85°C, 30 min. cycle, 5 cycles |
| Full Load Voltage | | Rated Voltage, 85°C, 1000 hr |
| Solder Leach Resistance | | 260±5°C, 10±1sec. |

I_L – Leakage current at rated voltage, the maximum leakage current was measured after reliability test.

Package

| Size EIA (EIAJ) | 1004 (2510) | 1210 (3025) |
|--|-------------|-------------|
| Standard Packing Quantity (pcs / reel) | 5,000 | 4,000 |

Specifications



Features

- SMD type silicon based chip
- Quick response time (<1ns)
- Low leakage current and clamping voltage
- Low capacitance can meet high speed single transient voltage protection
- Protect multiple I/O lines and one V_{cc} line
- Small package to save board space
- Meet IEC 61000-4-2 standard Level 4 for ESD 15kV (Air), 8kV (Contact)
- Solid-state silicon-avalanche technology
- Lead free type

Applications

- Low Capacitance Product Applications for High-Speed Signal Lines such as HDMI, DVI, USB and IEEE1394 Port etc.
- Applications for I/O Port (RS232, USB, PS2, VGA, Audio) on Mother Board and Notebook, Set-Top Box, MP3 Players, DVD Players, and Docking System etc.

How to Order

TV N 0402 01 AB1
1 2 3 4 5

- 1 Series Type: TV-TVS Diode
- 2 Capacitance Code
- 3 Package Size Code
- 4 Channel Code: 02-2 Channels, 01-1 Channel
- 5 Specialized Specification Code

Specifications

| P/N | Package | Capacitance | V _B (Reverse Breakdown Voltage) | V _{RWM} (Reverse Stand-off Voltage) | Channel | Surge Clamping Voltage | ESD Contact/Air | RoHS | Direction |
|-------------------|-----------|-------------|--|--|---------|------------------------|-----------------|------|--------------|
| Units | | pF | Volts | Volts | | Volts | KV(Max.) | | |
| TVL 0201 01 AB0 | 0201 | 3 | 10 | 5 | 1 | 14 (IPP=1A) | 8/15 | Yes | Bi-direction |
| TVL 0402 01 AB1 | 0402 | 6 | 10 | 6 | 1 | 14 (IPP=1A) | 8/15 | Yes | Bi-direction |
| TVN 0201 01 AB0 | 0201 | 20 | 10 | 5 | 1 | 13 (IPP=1A) | 8/15 | Yes | Bi-direction |
| TVH 0402 01 AB1 | 0402 | 35 | 6 | 5 | 1 | 10 (IPP=1A) | 8/15 | Yes | Bi-direction |
| TVN 0402 01 AB1 | 0402 | 50 | 10 | 5 | 1 | 12 (IPP=1A) | 8/15 | Yes | Bi-direction |
| TVW DF14 06 AD0* | DFN14 | 0.3 | 6 | 5 | 6 | - | 8/15 | Yes | - |
| TVQ DF10 04 AD0* | DFN10 | 0.35 | 6 | 5 | 4 | 8.5 (IPP=1A) | 8/15 | Yes | - |
| TVW MSOP 06 AD0* | MSOP-8L | 0.4 | 6 | 5 | 6 | 8.5 (IPP=1A) | 8/15 | Yes | - |
| TVW DF10 04 AD0 | DFN10 | 0.5 | 6 | 5 | 4 | 8.5 (IPP=1A) | 8/15 | Yes | - |
| TVU FB02 01 AD0 | FBP-02 | 0.5 | 6.2 | 5 | 1 | 8 (IPP=1A) | 10/15 | Yes | - |
| TVW ST23 04 AD0 | SOT23-6L | 0.55 | 6 | 5 | 4 | 8.5 (IPP=4.7A) | 12/19 | Yes | - |
| TVL ST23 04 AD0 | SOT23-6L | 1.0 | 6 | 5 | 4 | 8 (IPP=5A) | 8/15 | Yes | - |
| TVL FB02 01 AD0* | FBP-02 | 1.0 | 6 | 5 | 1 | 5 (IPP=5A) | 10/15 | Yes | Bi-direction |
| TVL S143 02 AC0 | SOT143-4L | 1.2 | 6.2 | 5 | 2 | 8.1 (IPP=5A) | 12/17 | Yes | - |
| TVL SC70 04 AC0 | SC70-6L | 1.3 | 6 | 5 | 4 | 8.1 (IPP=5A) | 12/17 | Yes | - |
| TVN S523 01 AB0 | SOD523-2L | 11.5 | 6.1 | 5 | 1 | 7 (IPP=5A) | 15/22 | Yes | Bi-direction |
| TVN ST23 02 AB0 | SOT23-3L | 12 | 6.1 | 5 | 2 | 7 (IPP=5A) | 15/22 | Yes | - |
| TVN ST523 02 AA0* | SOT-523 | 30 | 6.2 | 5 | 2 | 12 (IPP=5A) | 20/20 | Yes | - |

V_B – Measured voltage at any I/O pin to Ground at 1mA DC current. IPP–Maximum peak current in 8/20ms waveform.

C_p – Device capacitance measured with zero volt bias at 1MHz.

* – Preliminary

General Technical Data

| | |
|-----------------------|--------------------|
| Operating Temperature | -55°C ~ +85°C |
| Storage Temperature | -55°C ~ +150°C |
| Response Time | <1 ns |
| Solderability | 245 ± 5°C, 3±1sec. |

Environmental Performance

| Item | Specifications | Test Condition |
|-------------------------|--|--|
| Bias Humidity | $I_L \leq 10\mu A$ | 90%RH, 40°C, Working Voltage, 1000 hrs |
| Thermal Shock | | -40°C to 85°C, 30 min. cycle, 5 cycles |
| Full Load Voltage | | Working Voltage, 85°C, 1000 hrs |
| Solder Leach Resistance | (1) $I_L \leq 10\mu A$ at Working Voltage (2) Solder Wetting Area $\geq 95\%$ | 260±5°C, 10±1sec. |

Typical Characteristics

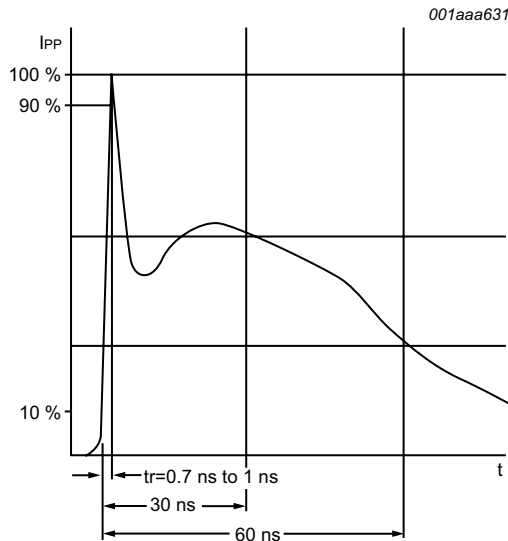

ESD Pulse Waveform
According to IEC 61000-4-2

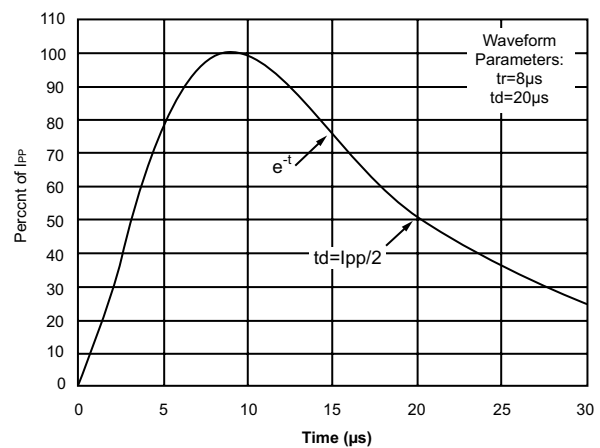



Surge (8/20 μ sec) Pulse Waveform

Pin Configuration and Circuit Diagram

| Part Number | Package | Pin Configuration | Circuit Diagram |
|-----------------|----------|-------------------|-----------------|
| TVL 0201 01 AB0 | 0201 | | |
| TVN 0201 01 AB0 | | | |
| TVL 0402 01 AB1 | 0402 | | |
| TVH 0402 01 AB1 | | | |
| TVN 0402 01 AB1 | | | |
| TVQ DF10 04 AD0 | DFN10 | | |
| TVW MSOP 06 AD0 | MSOP-8L | | |
| TVW DF10 04 AD0 | DFN10 | | |
| TVW ST23 04 AD0 | SOT23-6L | | |
| TVL ST23 04 AD0 | | | |

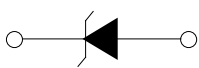
Pin Configuration and Circuit Diagram

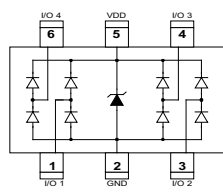
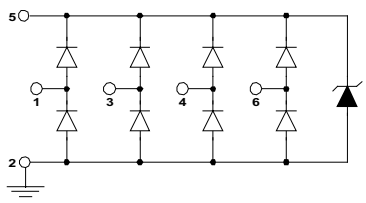
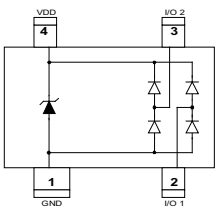
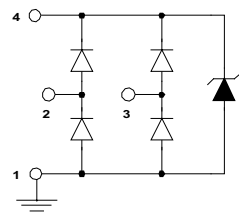
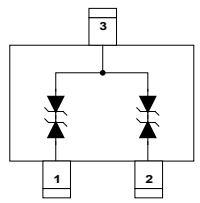
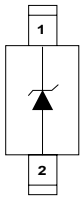
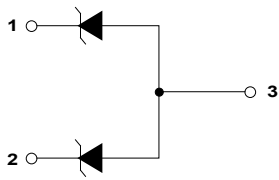
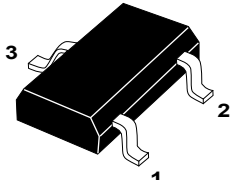
| Part Number | Package | Pin Configuration | Circuit Diagram |
|------------------|-----------|---|---|
| TVU FB02 01 AD0 | FBP-02 |  |  |
| TVL SC70 04 AC0 | SC70-6L |  |  |
| TVL S143 02 AC0 | SOT143-4L |  |  |
| TVN ST23 02 AB0 | SOT23-3L |  | |
| TVN S523 01 AB0 | SOD523-2L |  | |
| TVN ST523 02 AA0 | SOT-523 |  |  SOT-523 |

Package Dimension

Unit: mm

| Package | Length | | Width | | Thickness | |
|-----------|--------|------|-------|------|-----------|------|
| | Min. | Max. | Min. | Max. | Min. | Max. |
| 0201 | 0.55 | 0.65 | 0.25 | 0.35 | 0.25 | 0.35 |
| 0402 | 1 | 1.2 | 0.4 | 0.6 | 0.4 | 0.6 |
| FBP-02 | 0.95 | 1.05 | 0.55 | 0.65 | 0.45 | 0.55 |
| SOD523-2L | 1.1 | 1.3 | 0.7 | 0.9 | 0.5 | 0.7 |
| SC70-6L | 1.9 | 2.1 | 1.15 | 1.35 | 0.9 | 1.1 |
| SOT23-3L | 2.84 | 3 | 1.2 | 1.4 | 0.95 | 1.17 |
| SOT23-6L | 2.84 | 3 | 1.5 | 1.7 | 0.95 | 1.45 |
| SOT-523 | 1.5 | 1.7 | 1.45 | 1.75 | 0.7 | 0.9 |
| SOT143-4L | 2.8 | 3.04 | 1.2 | 1.4 | 0.95 | 1.17 |
| MSOP-8L | 4.7 | 5.1 | 2.8 | 3.2 | - | 1.1 |
| DFN10 | 2.4 | 2.6 | 0.9 | 1.1 | 0.55 | 0.65 |

Package

| Package Size | 0201 | 0402 | FBP-02 | SOD523 | SC70 | SOT23 | SOT-523 | SOT143 | MSOP-8L | DFN14 | DFN10 |
|---------------------------------------|--------|--------|--------|--------|-------|-------|---------|--------|---------|-------|-------|
| Standard Packing Quantity (pcs /reel) | 15,000 | 10,000 | 5,000 | 4,000 | 3,000 | 3,000 | 3,000 | 3,000 | 3,000 | 3,000 | 3,000 |



Features

- SMD type zinc oxide based ceramic chip
- Lead free plating termination provided good solderability characteristic
- Insulator overcoat keeps excellent low and stable leakage current
- Quick response time (<1ns)
- Low clamping voltage
- High transient current capability
- Meet IEC 61000-4-2 standard
- Compact size for EIA 0201/0402/0603/1206

Applications

- **Applications** for Mother Board, Notebook, Cellular Phone, PDA, handheld device, DSC, DV, Scanner, and Set-Top Box...etc.
- **Suitable** for Push-Button, Power Line and Low Frequency single line over voltage protect.

How to Order

MLV **S** **0201** **V05** - **330**

1 2 3 4 5

- 1 Series Type : MLV — Multilayer Varistor
- 2 Model Code
- 3 Chip Size (EIA) : 0201
- 4 Working Voltage : V_{DC}
- 5 Capacitance : Value — $XX \times 10^N \rightarrow XXN$
ex: 33pF= $33 \times 10^0 \rightarrow 330$

MLV **S** **1206** **M** **04** - **362**

1 2 3 4 5 6

- 1 Series Type : MLV — Multilayer Varistor
- 2 Model Code
- 3 Chip Size (EIA) : 0402 / 0603 / 1206
- 4 Varistor Voltage Tolerance :
M — 20% ; K — 10%
- 5 V_{RMS} : AC Working Voltage V_{RMS}
- 6 Capacitance : Value — $XX \times 10^N \rightarrow XXN$
ex: 3600pF= $36 \times 10^2 \rightarrow 362$

Dimensions

Unit: mm

| Size EIA (EIAJ) | 0201 (0603) | 0402 (1005) | 0603 (1608) | 1206 (3216) |
|-----------------|-------------|-------------|-------------|-------------|
| L | 0.60±0.05 | 1.00±0.15 | 1.60±0.15 | 3.20±0.15 |
| W | 0.30±0.05 | 0.50±0.10 | 0.80±0.10 | 1.60±0.15 |
| T | 0.30±0.05 | 0.50±0.10 | 0.80±0.10 | 1.7 max. |
| C | 0.20±0.10 | 0.25±0.15 | 0.30±0.20 | 0.50±0.25 |

Circuit Symbol

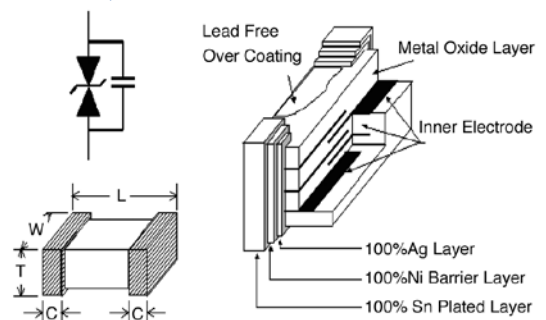

Specifications

| Symbol | Working Voltage | | Varistor Voltage | | Clamping Voltage | Capacitance | Peak Current | Transient Energy |
|------------------|-----------------|--------------|------------------|--------------|------------------|-------------|--------------|------------------|
| | V_{RMS} | V_{DC} | V_V | ΔV_V | V_C | C_p | i_{max} | W_{max} |
| Units | Volts | Volts (Max.) | Volts | V/% | Volts (Max.) | pF (typ.) | Amps (Max.) | Joules (Max.) |
| MLVS 0201 | | | | | | | | |
| MLVS0201V05330 | 4 | 5.5 | 11 | ±3V | 28 | 33 | - | - |
| MLVS 0402 | | | | | | | | |
| MLVS0402M04 | 4 | 5.5 | 8 | ±20% | 19 | 270 | 20 | 0.05 |
| MLVS0402M07 | 7 | 9 | 12.5 | ±20% | 32 | 130 | 20 | 0.05 |
| MLVS0402K11 | 11 | 14 | 18 | ±10% | 38 | 90 | 20 | 0.05 |
| MLVS 0603 | | | | | | | | |
| MLVS0603M04 | 4 | 5.5 | 8 | ±20% | 19 | 270 | 30 | 0.1 |
| MLVS0603M07 | 7 | 9 | 12.5 | ±20% | 27 | 210 | 30 | 0.1 |
| MLVS0603K11 | 11 | 14 | 18 | ±10% | 35 | 150 | 30 | 0.1 |
| MLVS 1206 | | | | | | | | |
| MLVS1206M04-362 | 4 | 5.5 | 8 | ±20% | 19 | 3600 | 150 | 0.4 |
| MLVS1206K14-182 | 14 | 18 | 22 | ±10% | 40 | 1800 | 150 | 0.4 |
| MLVS1206K40-181 | 40 | 56 | 70 | ±10% | 110 | 180 | 200 | 1.0 |

V_{RMS} —Maximum AC operating voltage the varistor can maintain and not exceed 10 μ A leakage current for 0402,0603/50 μ A leakage current for 1206.

V_{DC} —Maximum DC operating voltage the varistor can maintain and not exceed 10 μ A leakage current for 0402,0603/50 μ A leakage current for 1206.

V_V —Voltage across the device measured at 1mA DC current.
Equivalent to V_B , "break down voltage."

V_C —Maximum peak current across the varistor with 8/20 μ s waveform and 1A pulse current.

C_p —Device capacitance measured with zero volt bias 1Vrms at 1MHz (0201 / 0402 / 0603) or 1KHz (1206).

i_{max} —Maximum peak current which may be applied with 8/20 μ s waveform without device failure.

W_{max} —Maximum energy which may be dissipated with the 10/1000 μ s waveform without device failure.

► **General Technical Data**

| | |
|--------------------------------|--|
| Operating Temperature | 0201, 0402, 0603: -40°C ~ +85°C / 1206: -55°C ~ +125°C |
| Storage Temperature (on board) | 0201, 0402, 0603: -40°C ~ +85°C / 1206: -55°C ~ +150°C |
| Response Time | <1 ns |
| Solderability | 245±5°C, 3±1sec. |
| Solder Leach Resistance | 260±5°C, 10±1sec. |

► **Environmental Performance**

| Item | Specifications | Test Condition |
|-------------------|-----------------------------------|---|
| Bias Humidity | $\Delta V_v / V_v \leq \pm 10 \%$ | 90%RH, 40°C, Working Voltage, 1000 hrs |
| Thermal Shock | | 0201 & 0402 & 0603: -40°C to 85°C, 30 min. cycle, 5 cycles 1206: -55°C to 125°C, 30 min. cycle, 5 cycles |
| Full Load Voltage | | 0201 & 0402 & 0603: Working Voltage, 85°C, 1000 hrs 1206: Working Voltage, 125°C, 1000 hrs |

► **Package**

| Size EIA (EIAJ) | 0201 (0603) | 0402 (1005) | 0603 (1608) | 1206 (3216) |
|--|-------------|-------------|-------------|-------------|
| Standard Packing Quantity (pcs / reel) | 15,000 | 10,000 | 4,000 | 4,000 |



Features

- Lead free type
- SMD type zinc oxide based ceramic chip
- Insulator over coat keeps excellent low and stable leakage current
- Plating termination provided good solderability characteristic
- Wide operating voltage range, VDC: 5.5V to 18V
- Quick response time (<1ns)
- Low clamping voltage
- Meet IEC 61000-4-2 standard
- Low capacitance can meet high speed single transient voltage protection

Applications

- Low capacitance product applications for high-speed signal lines such as HDMI, DVI, USB and IEEE1394 Port etc.
- Normal capacitance product applications for I/O Port (RS232, USB, PS2, VGA, Audio) on Mother Board and Notebook, Set-Top Box, MP3 Players, DVD Players, and Docking System etc.

How to Order

MLV **G** **0402** **3R0** **T** **V18**

1 2 3 4 5 6 7 8

- 1 Series Type : MLV — Multilayer Varistor
- 2 Model Code
- 3 Chip Size(EIA) : 0402 / 0603
- 4 Capacitance : Value- $XR_X=0.XpF$, ex: 3R0=1.0pF,
- 5 Capacitance Tolerance : T $\pm 1.4pF$, Q - $\pm 2.0pF$
- 6 Working Voltage : V_{DC}
- 7 Special Code
- 8 Special Code

Dimensions

Unit: mm

| Size EIA (EIAJ) | 0402 (1005) | 0603 (1608) |
|-----------------|-------------|-------------|
| L | 1.00±0.15 | 1.60±0.20 |
| W | 0.50±0.10 | 0.80±0.20 |
| T | 0.50±0.10 | 0.80±0.20 |
| C | 0.25±0.15 | 0.30±0.20 |

Circuit Symbol

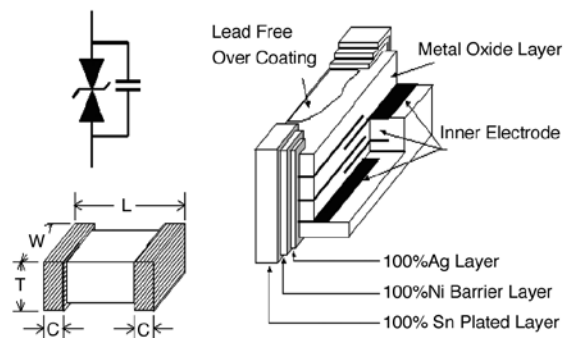

Specifications

| Symbol | Working Voltage V_{bc} | Varistor Voltage V_v | Clamping Voltage V_c | Capacitance C_p | Leakage Current I_L |
|-------------------|-----------------------------|---------------------------|---------------------------|----------------------|--------------------------|
| Units | Volts (Max.) | Volts | Volts (Max.) | pF | μA (Max.) |
| MLVG0402 | | | | | |
| MLVG04023R0TV18BP | ~18 | 22~34 | 58 | 3.0 | <10 |
| MLVG04025R0QV18BP | ~18 | 22~34 | 58 | 5.0 | <10 |
| MLVG0603 | | | | | |
| MLVG06033R0TV18BP | ~18 | 22~34 | 58 | 3.0 | <10 |
| MLVG06035R0QV18BP | ~18 | 22~34 | 58 | 5.0 | <10 |

V_{bc} – Maximum DC operating voltage the varistor can maintain and not exceed 10 μA leakage current.

V_v – Voltage across the device measured at 1mA DC current.

Equivalent to V_b , "break down voltage."

V_c – Maximum peak current across the varistor with 8/20 μs waveform and 1A pulse current.

C_p – Device capacitance measured with zero volt bias 1Vrms at 1MHz.

General Technical Data

| | |
|--------------------------------|-------------------------------|
| Operating Temperature | -40°C ~ +85°C |
| Storage Temperature (on board) | -40°C ~ +85°C |
| Response Time | <1 ns |
| Solderability | 245 \pm 5°C, 3 \pm 1sec. |
| Solder Leach Resistance | 260 \pm 5°C, 10 \pm 1sec. |

Environmental Performance

| Item | Specifications | Test Condition |
|-------------------|-----------------------------------|--|
| Bias Humidity | $\Delta V_v / V_v \leq \pm 10 \%$ | 90%RH, 40°C, Working Voltage, 1000 hrs |
| Thermal Shock | | -40°C to 85°C, 30 min. cycle, 5 cycles |
| Full Load Voltage | | Working Voltage, 85°C, 1000 hrs |

Package

| Size EIA (EIAJ) | 0402 (1005) | 0603 (1608) |
|--|-------------|-------------|
| Standard Packing Quantity (pcs / reel) | 10,000 | 4,000 |



Features

- Lead free type
- SMD type zinc oxide based ceramic chip
- Insulator overcoat keeps excellent low and stable leakage current
- Plating termination provided good solder-ability characteristic
- Wide operating voltage range
- Quick response time (<1ns)
- Low clamping voltage
- Meet IEC 61000-4-2 standard
- Low capacitance can meet high speed single transient voltage protection

Applications

Applications for I/O Port such as RS232, USB, PS2, VGA, Audio on Mother Board and Notebook, Set-Top Box, MP3 Players, DVD Players, and Docking System etc.

Low Capacitance Product Applications for High Speed I/O port such as HDMI, DVI, USB, and IEEE1394 etc.

How to Order

ML **F** **0402** **100** **V05** □ □ □
1 2 3 4 5 6 7 8

- 1 Series Type : ML — Multilayer Varistor
- 2 Model Code
- 3 Chip Size (EIA) : 0402/0603
- 4 Capacitance: Value-XXR=0.XpF,Ex:0R5=0.5pF;
XXx10N→XXN Ex: 10pF=10x100→100
- 5 Working Voltage : VDC
- 6 Special Code
- 7 Special Code
- 8 Special Code

Dimensions

Unit: mm

| Size EIA (EIAJ) | 0402 (1005) | 0603 (1608) |
|-----------------|-------------|-------------|
| L | 1.00±0.10 | 1.60±0.20 |
| W | 0.50±0.10 | 0.80±0.15 |
| T | 0.50±0.10 | 0.80±0.10 |
| C | 0.25±0.15 | 0.40±0.20 |

Circuit Symbol

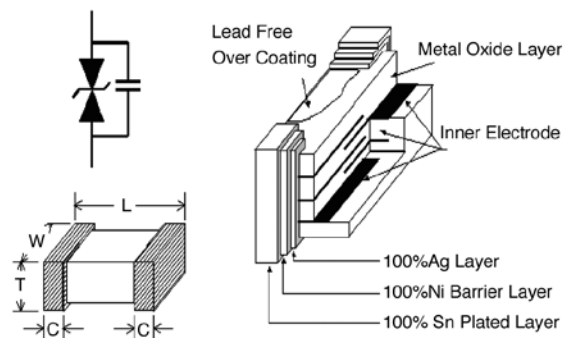

Specifications

| Part Number | Working Voltage | Clamping Voltage | Breakdown Voltage | | Leakage Current R.T. (15~35°C) | | Capacitance @ 1 V(rms) | | | | Peak Current |
|-------------|-----------------|------------------|-------------------|-----|--------------------------------|--------------|------------------------|-----|-----------|-----|--------------|
| | D.C (V) | 8/20µs (V) | DC @1mA (V) | | Voltage (V) | Current (µA) | 1MHZ (pF) | | 1KHZ (pF) | | 8/20µs (A) |
| | max | max | min | max | | | min | max | min | max | max |
| | | | | | | | | | | | |

| MLF 0402 | | | | | | | | | | | | |
|---------------|-----|-----|------|------|---|-----|-------|-------|-------|------|----|--|
| MLF04023R0V18 | 18 | 130 | 50 | 80 | 3 | 0.3 | 2.4 | 5.4 | 4 | 9 | 2 | |
| MLF04025R0V18 | 18 | 66 | 24 | 32 | 3 | 0.3 | 2.09 | 8.8 | 6.8 | 13 | 3 | |
| MLF0402100V18 | 18 | 66 | 24 | 32 | 3 | 0.3 | 3.42 | 14.4 | 10.2 | 19.5 | 3 | |
| MLF0402330V05 | 5.5 | 22 | 10 | 14 | 3 | 3 | 7.6 | 32 | 22.44 | 42.9 | 4 | |
| MLF0402101V05 | 5.5 | 22 | 10 | 14 | 3 | 3 | 22.8 | 96 | 68 | 130 | 10 | |
| MLF0402201V09 | 9 | 22 | 10.2 | 13.8 | 3 | 3 | 45.6 | 192 | 136 | 260 | 15 | |
| MLF0402481V05 | 5.5 | 18 | 7.2 | 10.8 | 3 | 3 | 110.2 | 464 | 326.4 | 624 | 20 | |
| MLF 0603 | | | | | | | | | | | | |
| MLF06033R0V18 | 18 | 130 | 50 | 80 | 3 | 0.3 | 2.4 | 5.4 | 4 | 9 | 2 | |
| MLF06035R0V09 | 9 | 36 | 18 | 24 | 3 | 3 | 2.09 | 8.8 | 6.12 | 11.7 | 3 | |
| MLF0603100V18 | 18 | 66 | 24 | 32 | 3 | 0.3 | 2.28 | 9.6 | 6.8 | 13 | 5 | |
| MLF0603150V18 | 18 | 66 | 24 | 32 | 3 | 0.3 | 3.8 | 16 | 10.2 | 19.5 | 3 | |
| MLF0603241V22 | 22 | 56 | 24.3 | 29.7 | 3 | 0.3 | 54.7 | 230.4 | 163.2 | 312 | 20 | |
| MLF0603301V05 | 5.5 | 18 | 7.2 | 10.8 | 3 | 3 | 68.4 | 288 | 204 | 390 | 30 | |
| MLF0603301V18 | 18 | 56 | 21.6 | 26.4 | 3 | 0.3 | 68.4 | 288 | 204 | 390 | 20 | |
| MLF0603471V05 | 5.5 | 20 | 10 | 14 | 3 | 3 | 106.4 | 448 | 319.6 | 611 | 30 | |
| MLF0603901V05 | 5.5 | 18 | 7.2 | 10.8 | 3 | 3 | 205.2 | 864 | 612 | 1170 | 30 | |

General Technical Data

| | |
|--------------------------------|-------------------|
| Operating Temperature | -40°C ~ +85°C |
| Storage Temperature (on board) | -40°C ~ +85°C |
| Response Time | <1 ns |
| Solderability | 245±5°C, 3±1sec. |
| Solder Leach Resistance | 260±5°C, 10±1sec. |

Environmental Performance

| Item | Specifications | Test Condition |
|-------------------|-----------------------------------|--|
| Bias Humidity | $\Delta V_v / V_v \leq \pm 10 \%$ | 90%RH, 40°C, Working Voltage, 1000 hrs |
| Thermal Shock | | -40°C to 85°C, 30 min. cycle, 5 cycles |
| Full Load Voltage | | Working Voltage, 85°C, 1000 hrs |

Package

| Size EIA (EIAJ) | 0402 (1005) | 0603 (1608) |
|--|-------------|-------------|
| Standard Packing Quantity (pcs / reel) | 10,000 | 4,000 |



Features

- Dual function for EMI and ESD
- Compact size for EIA 0402 and 0603
- ESD protection for IEC61000-4-2 Level 4
- Fixed capacitance suitable for high-speed I/O port transient voltage protection
- RoHS Compliant

Applications

Applications for I/O Port for Mother Board and Notebook (RS232, USB, PS2, VGA, Audio), Set-Top Box, MP3 Players, DVD Players, and Docking System etc.

How to Order

VPORT **0402** **100** **M** **V05**

1 2 3 4 5 6

- 1 Series Type : V—Over Voltage Protection
PORT—EMI Protection for I/O Port
- 2 Chip Size(EIA) : 0402 / 0603
- 3 Capacitance : Value—XXx10^N → XXN
ex:10pF=10x10⁰ → 100
- 4 Capacitance Tolerance : M—20%
- 5 Working Voltage : 0402 → 5V
0603 → 5V/12V
- 6 Suffix for Special Code

Dimensions

Unit: mm

| Size EIA (EIAJ) | 0402 (1005) | 0603 (1608) |
|-----------------|-------------|-------------|
| L | 1.00±0.15 | 1.60±0.15 |
| W | 0.50±0.10 | 0.80±0.10 |
| T | 0.50±0.10 | 0.80±0.10 |
| C | 0.25±0.15 | 0.30±0.20 |

Circuit Symbol

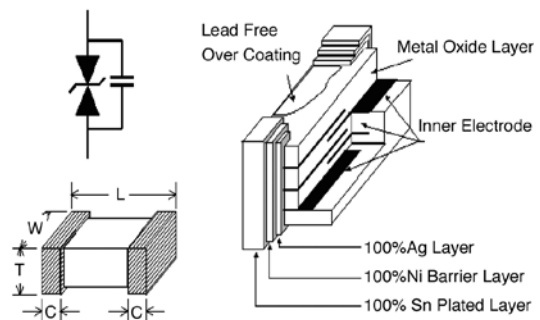

Specifications

General Characteristics (25±5°C)

| *Description | A | B | C | D | E | F | G |
|-----------------------------------|--------------------------------------|-----------------------------------|-------------------------------|------------------------------------|-----------------------|--------------------|----------------------------|
| Part Number | Operating Voltage (V _{oc}) | Leakage Current (I _L) | Capacitance (C _p) | Clamping Voltage (V _c) | Capacitance Tolerance | Dissipation Factor | Temperature Characteristic |
| VPORT 0402 XXXX V05 Series | | | | | | | |
| VPOR0402100MV05 | 5V | <15μA | 10 | 34 | M: ±20% | 4.0%max. | ΔC: +15%/-15% |
| VPOR0402220MV05 | | | 22 | 30 | | | |
| VPORT 0603 XXXX V05 Series | | | | | | | |
| VPOR0603100MV05 | 5V | <15μA | 10 | 34 | M: ±20% | 4.0%max. | ΔC: +15%/-15% |
| VPOR0603220MV05 | | | 22 | 30 | | | |
| VPORT 0603 XXXX V12 Series | | | | | | | |
| VPOR0603220MV12 | 12V | <15μA | 22 | 42 | M: ±20% | 4.0%max. | ΔC: +15%/-15% |
| VPOR0603470MV12 | | | 47 | 38 | | | |
| VPOR0603151MV12 | | | 150 | 35 | | | |

*Description

| Item | Description |
|------|--|
| A | Max. Continuous Operating Voltage (V _{oc}). |
| B | Leakage Current (I _L). Measured at rated continuous operating voltage. |
| C | Capacitance (C _p) . The test condition is 1KHz (≥100pF) /1MHz (<100pF) 1Vrms ±10% and the environment temperature is 25±2°C. |
| D | Max. Clamping voltage (V _c). Maximum peak current across the chip with 8/20μs waveform and 1A pulse current. |
| E | Capacitance Tolerance. Capacitance Tolerance, M=±20%. |
| F | Dissipation Factor. |
| G | Temperature Characteristic. -30°C ~ +85°C. |

General Technical Data

| | |
|--------------------------------|-------------------|
| Operating Temperature | -40°C ~ +85°C |
| Storage Temperature (on board) | -40°C ~ +85°C |
| Response Time | <1 ns |
| Solderability | 245±5°C, 3±1sec |
| Solder Leach Resistance | 260±5°C, 10±1sec. |

Environmental Performance

| Item | Specifications | Test Condition |
|-------------------|---|--|
| Bias Humidity | (1) $I_L \leq 15\mu A$ at Working Voltage (2) $\Delta C_p/C_p \leq \pm 10\%$ | 90%RH, 40°C, Working Voltage, 1000 hrs |
| Thermal Shock | | -40°C to 85°C, 30 min. cycle, 5 cycles |
| Full Load Voltage | | Working Voltage, 85°C, 1000 hrs |

Package

| Size EIA (EIAJ) | 0402 (1005) | 0603 (1608) |
|--|-------------|-------------|
| Standard Packing Quantity (pcs / reel) | 10,000 | 4,000 |



INPAQ TECHNOLOGY CO., LTD.

SALES SITE

HEADQUARTERS

No.11, Ke-Yi St., Chunan, Miaoli 35059, Taiwan
TEL: +886-37-585-555
FAX: +886-37-585-511
E-Mail: info@inpaq.com.tw
<http://www.inpaq.com.tw>
<http://www.inpaqgp.com>

TAIPEI OFFICE

Rm. 19, 5F., No.6, Ln. 180, Sec. 6, Mincuan E. Rd.,
Neihu Dist., Taipei City 11490, Taiwan
TEL: +886-2-2793-1411
FAX: +886-37-585-511 ext: (Receiver's Extension)

SUZHOU OFFICE

No. 1800 Zhongshan West Road, 4th Floor, Zhao
Feng Universe Building Block D, Xuhui District,
Shanghai City 200235, Jiangsu Province, China
TEL: +86-21-6440-0398
FAX: +86-21-6440-0138

SHENZHEN OFFICE

Room 402, Bld.212, Tairan Industrial Zone,
CheGongMiao, FuTian District, Shenzhen City
518040, Guangdong Province, China
TEL: +86-755-8279-4585
FAX: +86-755-8279-4565

KOREA OFFICE

221 Raemian Seocho Univill, 1445-4, Seocho-Dong,
Seocho_Gu, Seoul 130-070, Korea
TEL: +82-2-584-8959
FAX: +82-2-584-8951

USA OFFICE

21 Echo Brook Road, Rochester, NH 03839, U.S.A.
TEL: +1-603-332-6222
FAX: +1-603-509-2900



Circuit Protection